

iControls

PULSE *Direct Drive DC Door Operators*
PULSE *with Battery Backup*



PULSE 200 SERIES

Commercial Direct Drive Door Operator for Balanced Sectional and Rolling Steel Doors. Installation Manual and Setup/User Instructions

U.S. Patent No. 11105138

35 East Beaver Creek Rd., Unit 1 Richmond Hill, Ontario Canada L4B 1B3
905-597-8989 • www.icontrols.ca • sales@icontrols.ca
PULSE TECHNICAL SUPPORT LINE: 1-833-PULSEDC (1-833-785-7332)

TABLE OF CONTENTS

- General Overview..... Page 3
- Compliance with UL 325 Requirements..... Page 3
- Box Inventory..... Page 3
- Operator Technical Overview..... Pages 3-4
- Pre-Installation Assembly Requirements..... Pages 5-6
- Mounting Installation Instruction..... Pages 7-9
- Wiring Information..... Page 10-11
- Wiring Diagram..... Page 11
- Startup Procedure..... Page 12
 - Powering Up..... Page 12
- SETUP MENU Access and Settings..... Page 12-17
 - Set Door Limits..... Page 12-13
 - Set Door Speed..... Page 13
 - Set Closing Timer..... Page 13
 - Set Closing Force..... Page 14
 - Set Opening Force..... Page 14
 - Set Open Rampdown Distance..... Page 14
 - Set Close Rampdown Distance..... Page 14
 - Set Open Slow Speed..... Page 14
 - Set Close Slow Speed..... Page 14
 - Set PWM Frequency..... Page 15
 - Set Output Relay Options..... Page 15
 - Set Lock Output..... Page 15
 - Using Jog Mode..... Page 15
 - Calibration..... Page 15-16
 - Run Balance Check..... Page 16
 - Factory Reset/Factory Settings..... Page 16
 - Exiting SETUP Menu..... Page 16-17
- Power Outage Operation..... Page 17
- Battery Information..... Page 17
- Car Wash/Water Resistant Applications..... Page 17
- Remote Transmitters..... Page 17
- Components..... Page 18
- Troubleshooting Guide..... Page 19-21
- Replacement Parts List..... Page 21
- Warranty..... Page 22

GENERAL OVERVIEW

Thank you for purchasing this Pulse 200 Series Direct Drive Door Operator. This dependable operator is designed for medium-cycle duty of your Commercial or Residential Door. Quick and easy to install, this operator helps extend the life of your counter-balanced door with its integrated soft-start/soft-stop capability.

It features adjustable opening speeds of up to approximately 24" per second, a patented battery backup system that can operate the door in case of power failure, and adjustable auto-reversing force monitoring, along with a variety of other helpful programmable functions.

FULLY COMPLIANT with UL 325:2023 REQUIREMENTS

This Pulse Operator is provided with a Polarized Reflective Photo-Eye. This must be installed to meet UL325 requirements. Once the Close button is activated, the operator verifies that the Photo-Eye is connected and functional, is not bypassed by means of a jumper, and it continues to monitor the sensor as the door closes.

These operators are also compatible with monitored reversing devices. The 'Reversing In' input on board automatically senses whether the connected reversing device is a monitored or non-monitored device, and behaves accordingly.

This operator also has adjustable Force Monitoring on the open and close cycle to act as a secondary safety/reversing entrapment protection feature.

This operator will initiate Push/Hold to CLOSE protocols should the photo-eye be misaligned or is otherwise compromised. Note that during Push/Hold to Close protocols, the door will reverse should it not fully reach the closed limit per UL 325.

BOX INVENTORY

Before beginning installation, please verify that all components are accounted for:

1. Motor, Gearbox, Encoder, Multi-Conductor Cable (all pre-assembled)
2. Control Panel
3. Limit Brackets and Hardware (Angle Brackets for Stop Limit to mount on door tracks)
4. Torque Arm, Mounting Bolts, Mounting Bracket
5. 3 x 1/2" NPT Cable Glands (Strain Relief Cord Connectors) and Locknuts
6. Shaft Collar and Shaft Key
7. Reversing Device - Reflective Photo-eye (Thru-Beam Photo-Eye included on '-WP' Models)
8. Two 12V, 2.3Ah Lead-Acid Rechargeable Batteries (pre-mounted behind board).

In case any of the above items is missing, please contact iControls and provide us with details of the missing part(s), as well as the serial number of your operator.

OPERATOR TECHNICAL OVERVIEW

Motor			
HORSEPOWER:	Pulse 238 = 3/8 HP	Pulse 250 = 1/2 HP	
SPEED:	1750 RPM		
CURRENT (FLA):	3/8 HP = 4A	1/2 HP = 5A	
OUTPUT TORQUE:	Pulse 238: 30:1=27.6Nm, 40:1=36.8Nm, 50:1=46.0Nm	Service Factor 1.6	
	Pulse 250: 30:1=36.8Nm, 40:1=49.1Nm, 50:1=61.3Nm	Service Factor 1.6	

Electrical

SUPPLY VOLTAGE:	110-130, 1ph Input
BATTERIES:	2 x 2.3Ah, 12Vdc
CONTROL VOLTAGE:	24Vdc, 0.8A Power/Connections supplied for activation and reversing devices
AUX RELAY:	1 SPDT Programmable Relay (factory default to activate on Open Limits)

Safety

PHOTO-EYE SENSOR:	Polarized Photo-eye Sensor/Reflector with Bracket provided with unit as non-impact reversing device protection.
POWER OUTAGE OPERATION:	Battery Backup to open/close the door in case of power-outage. 3/8" ratchet socket for manual crank open/close as added redundancy.

IMPORTANT

WARNING - These instructions are intended for experienced personnel trained for service and installation of sectional doors and operators. All safety precautions and local codes must be followed.

1. READ AND FOLLOW ALL INSTALLATION INSTRUCTIONS.
2. Have qualified service personnel make necessary repairs to ensure door is operating smoothly without any unusual noise. Install operator only on a smoothly operating and well balanced door.
3. Remove all pull ropes and remove locks (unless mechanically and/or electrically interlocked to the power unit) connected to the door before installing the operator.
4. A commercial/industrial door operator that has exposed moving parts capable of causing injury to persons or employs a motor deemed indirectly accessible by clause 10.6 by virtue of its location above the floor shall include:
 - a. Install the door operator at least 2.44m (8 ft) or more above the floor: or
 - b. If the operator must be installed less than 2.44m (8ft) above the floor, then exposed moving parts must be protected by covers or guarding; or
 - c. Both a. and b.
5. Do not connect the operator to the supply power until instructed to do so.
6. Locate the push button station: (a) within sight of the door, and (b) at a minimum height of 1.53m (5 ft) above floors, landings, steps, or any other adjacent walking surface and (c) away from all moving parts.
7. Install an Entrapment Warning Placard next to the control station in a prominent location.

PRE-INSTALLATION ASSEMBLY REQUIREMENTS

BEFORE INSTALLATION, ENSURE THAT YOUR DOOR IS PROPERLY BALANCED AND RUNNING SMOOTHLY. ALSO ENSURE THAT THE LIMIT BRACKETS (SUPPLIED) ARE INSTALLED AND SECURED PROPERLY. BUMPER/PUSHER SPRINGS MAY BE USED IN PLACE OF, OR IN ADDITION TO LIMIT BRACKETS FOR PULSE OPERATORS, BUT MUST BE INSTALLED PRIOR TO OPERATION.

Operator Mounting Requirements

Pulse 200 Series operators are mounted directly anywhere on the door shaft. Before installing the operator, please ensure following criteria is met:

The door must be well balanced, and have been tested for smooth functioning without any unusual noises or snags.

Provided Limit Brackets are installed 4"-5" past door's desired open position, and within allowable maximum cable height, to prevent the doors from over-travel (See Fig. 1A). Bumper or Pusher Springs are acceptable as an alternate.

The door has a solid keyed shaft with a minimum exposed length of 4.5" on the operator side.

Clearance of at least 6" from end of shaft, and 18" vertically below the shaft. There is adequate structural support surface to securely install the torque arm mounting bracket/torque arm. For more details, see mounting installation instructions Fig: 1 & 7.

Mounting space for the control panel: Min. 5 ft. from ground level, within clear sight of the door but far enough away as to prevent users from coming into contact with moving parts.

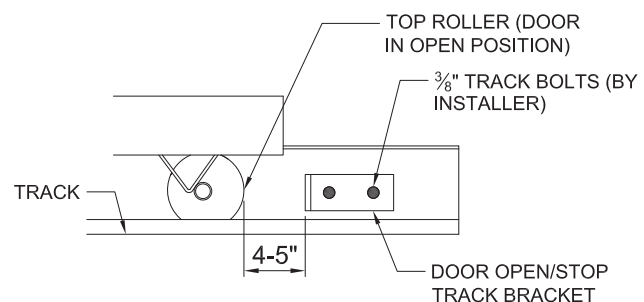
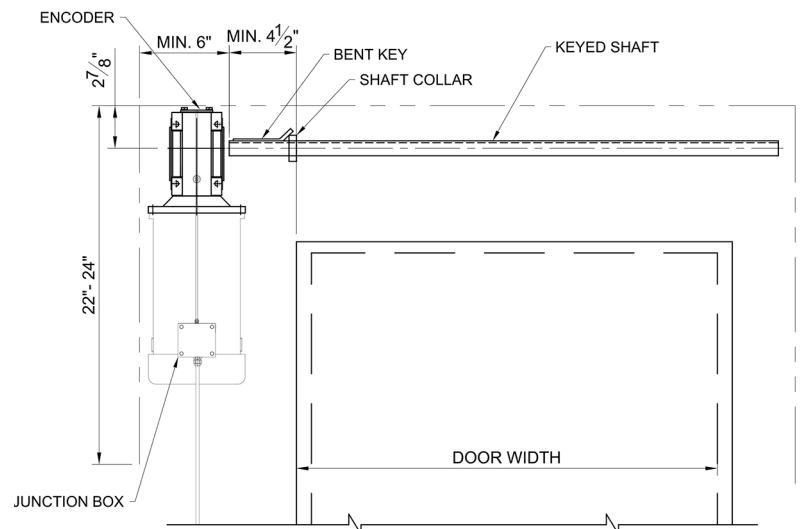

Assembling Torque Arm to Gearbox

The torque arm can be assembled onto either side of the gearbox using the enclosed 4 bolts. There are 6 possible angle positions for the torque arm, and its optimal mounting position should be pre-determined prior to assembly. Tighten bolts appropriately. THE TORQUE ARM IS AN INTRINSIC COMPONENT OF THE OPERATOR'S SAFETY AND FUNCTIONALITY AND MUST BE INSTALLED SECURELY. See Fig: 4

See below for recommendations on how to mount Torque Arm to Operator/ Mounting Bracket in relation to Shaft Off-set.

Torque Arm
11 Possible Positions

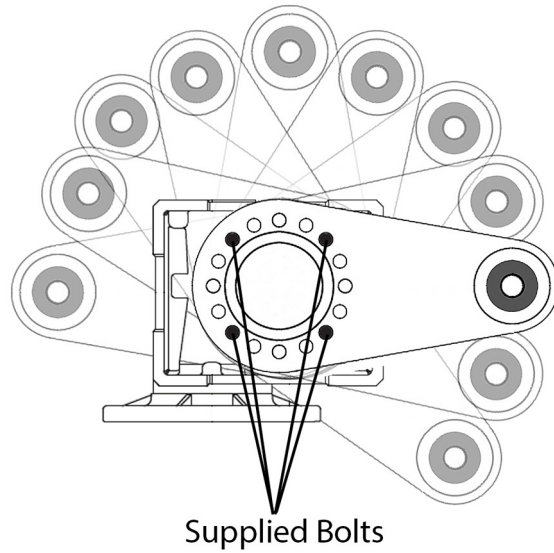

TORQUE ARM POSITION IN RELATION TO OPERATOR

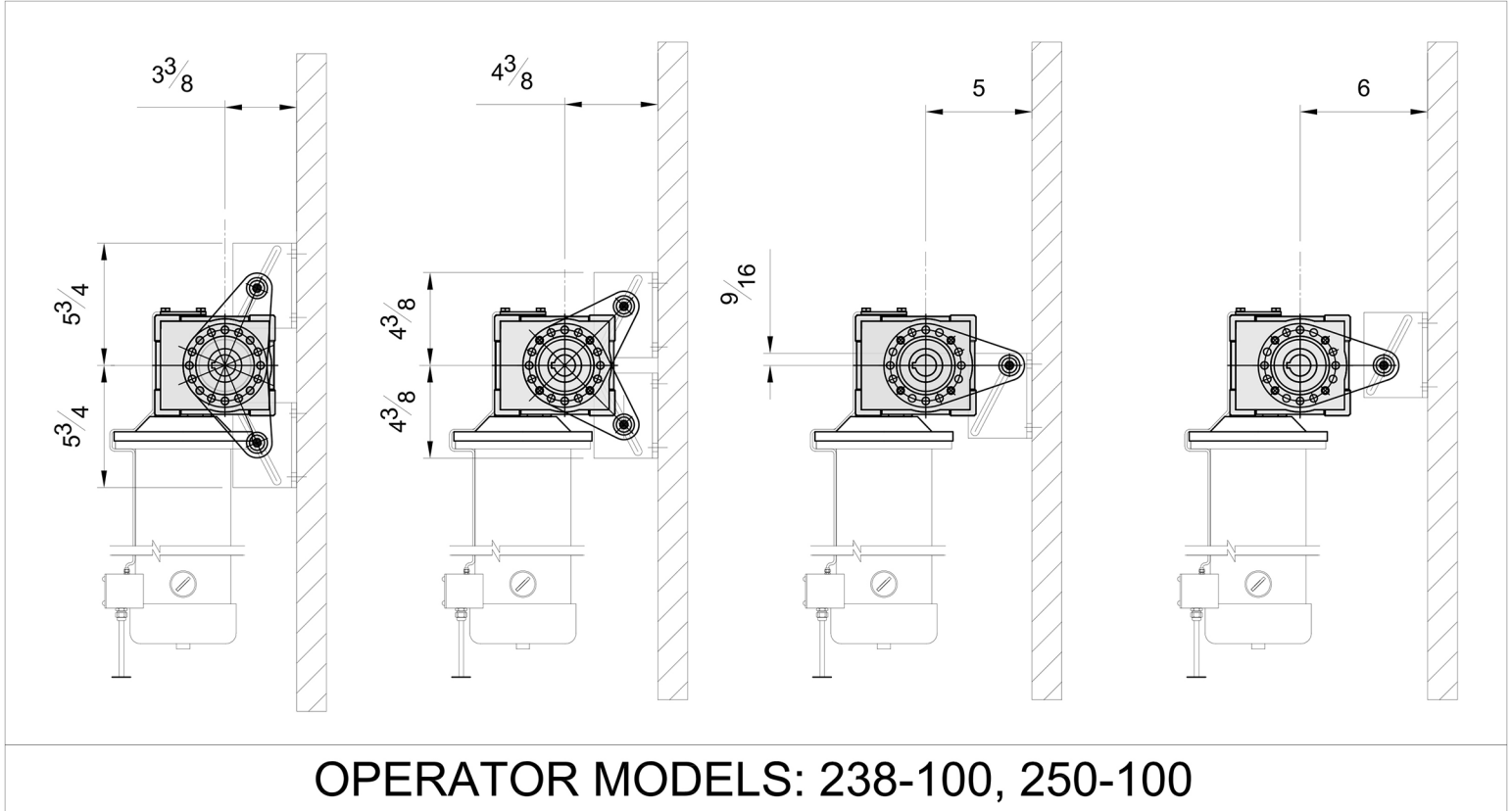

MOUNTING INSTALLATION INSTRUCTION

WARNING

- **TO REDUCE THE RISK OF PERSONAL INJURY OR DEATH, DO NOT CONNECT ELECTRICAL POWER UNTIL OPERATOR MOTOR, CONTROL PANEL AND PHOTO-EYE ARE INSTALLED, SECURED AND PROTECTED PER FOLLOWING INSTRUCTIONS.**
- **ENSURE THAT AREA IS CLEAR OF PERSONNEL AND CORDONED OFF TO ACCESS WHILE INSTALLING OPERATOR.**
- **USE PROPER SAFETY PROTOCOLS ACCORDING TO INTERNAL, LOCAL AND FEDERAL REQUIREMENTS.**

MANDATORY FIRST STEP - Limit Bracket Installation

If your door is not already equipped with bumper/pusher springs, it is mandatory to install the supplied Limit Brackets. Mount one bracket to the top of each track (See Figure 1A) to prevent over-travel of the door, and enable automatic encoder recalibration prior to setting limits (and possibly after an extended power-loss). These should be mounted inside the door-tracks at the door's maximum allowable travel point, and are required to be located at the same exact position on both tracks so that the top rollers of the door rest against them in a level position.

To install, manually open the door to the uppermost opening position allowable by the cables, clamp the door in place, and secure the brackets to the track as shown Figure 1A using the top rollers as the reference points for the brackets.

IN THE ABSENCE OF BUMPER/PUSHER SPRINGS, INSTALLATION OF LIMIT BRACKETS IS MANDATORY PRIOR TO OPERATOR INSTALLATION. WITHOUT PHYSICAL LIMITS, THE DOOR CAN RUN OUT OF ITS TRACKS AND CAUSE SEVERE PERSONAL INJURY AND/OR CAUSE SEVERE DAMAGE TO THE DOOR. FURTHERMORE, YOU WILL BE UNABLE TO SET THE LIMITS.

Shaft Collar/Bent Key Installation

The Shaft Collar serves as an end-stop for the bent shaft key to prevent it from back-travel out of the keyed shaft and from rubbing on the bearing plate. It needs to be mounted in conjunction with the key as shown in diagram.

Adjust the door so that the shaft keyway is facing up (you may have to open/wedge/clamp the door open slightly to achieve this).

Loosen the Shaft Collar set screw and slide the collar over the shaft close to the bearing plate, but not so close as to touch it. Firmly tighten the set screw.

Insert the 3 inch bent shaft key (provided with operator) into the door shaft keyway with the bent end facing the installed shaft collar.

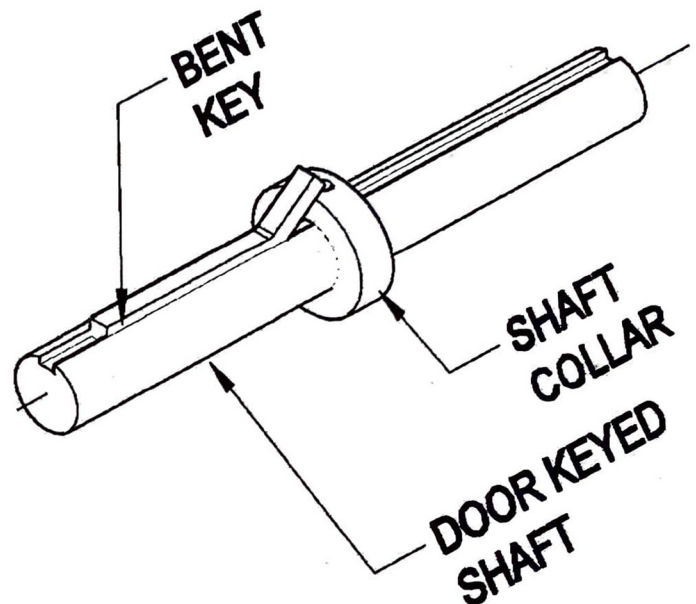

Operator Installation

WARNING

WARNING: THE OPERATOR ASSEMBLY IS HEAVY AND CAN CAUSE SERIOUS INJURY OR DEATH SHOULD IT BE DROPPED DURING INSTALLATION. TAKE ALL NECESSARY SAFETY PRECAUTIONS TO AVOID DROPPING THE OPERATOR (I.E. TETHER/TIE DOWN) PRIOR TO ATTEMPTING INSTALLATION. SCAFFOLDING OR SCISSOR-LIFTS/ PLATFORM-LIFTS ARE ADVISED FOR OPERATOR INSTALLATION. NEVER ATTEMPT TO INSTALL AN OPERATOR ABOVE EYE-LEVEL OR FROM A LADDER.

ENSURE THAT PREVIOUS STEPS FOR SHAFT COLLAR/BENT KEY INSTALLATION HAVE BEEN PROPERLY FOLLOWED BEFORE PROCEEDING.

Align the keyway of the gearbox with the pre-mounted bent key (see Key Shaft Collar/Key Installation on previous page) located on the mounting side of the shaft. Bent section of key should face the shaft collar as noted in previous instructions.

Adjust the keyway of the hollow gearbox so that it is facing upwards (use a 3/8" ratchet placed in the bottom entry of the operator to move to rotate the hollow gearbox). Slide the gearbox onto the shaft until it makes contact with the bend radius of the key.

Fasten the torque arm to structural support by means of the supplied bolt, locking nut and washers. The supplied bracket may be required. If the torque arm does not align with structural support, you may try adjusting the torque arm position on the gearbox (see Assembling Torque Arm to Gearbox) accordingly or use the provided Torque Arm Bracket.

If the Torque Arm Bracket is needed, pre-assemble the bracket to the Torque arm using the provided fasteners prior to sliding on the operator (NOTE: DO NOT TIGHTEN THE NUT FULLY). Locate the proper position for the bracket on solid structural support (i.e. wall), mark the mounting holes, and install anchors as required (you may need to remove the operator to do this). Fasten the bracket to the support, then tighten the Torque Arm Bolt.

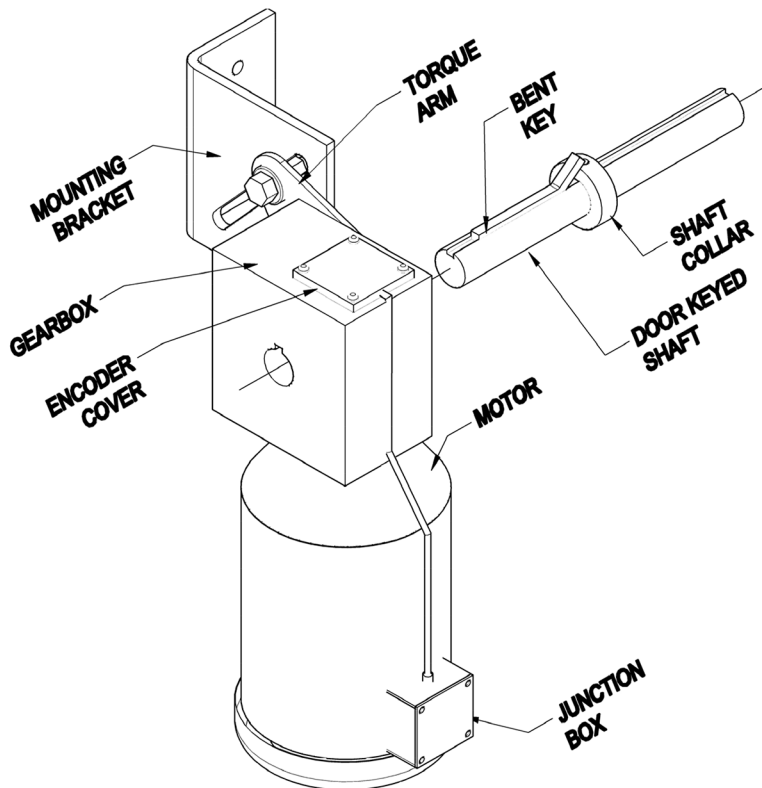

FAILURE TO SECURELY FASTEN TORQUE ARM COULD RESULT IN DAMAGE, SERIOUS INJURIES OR DEATH AND WILL VOID THE WARRANTY.

Control Panel Mounting

The control panel should be securely mounted at or around eye level (minimum 5 ft. from floor) on the same side as the operator/junction box. Ensure that the control panel is mounted far enough away from the door as to avoid user contact with the door while in operation, but close enough that the user has clear view of the door at all times. Four (4) control mounting brackets are provided to facilitate mounting. See Fig: 8

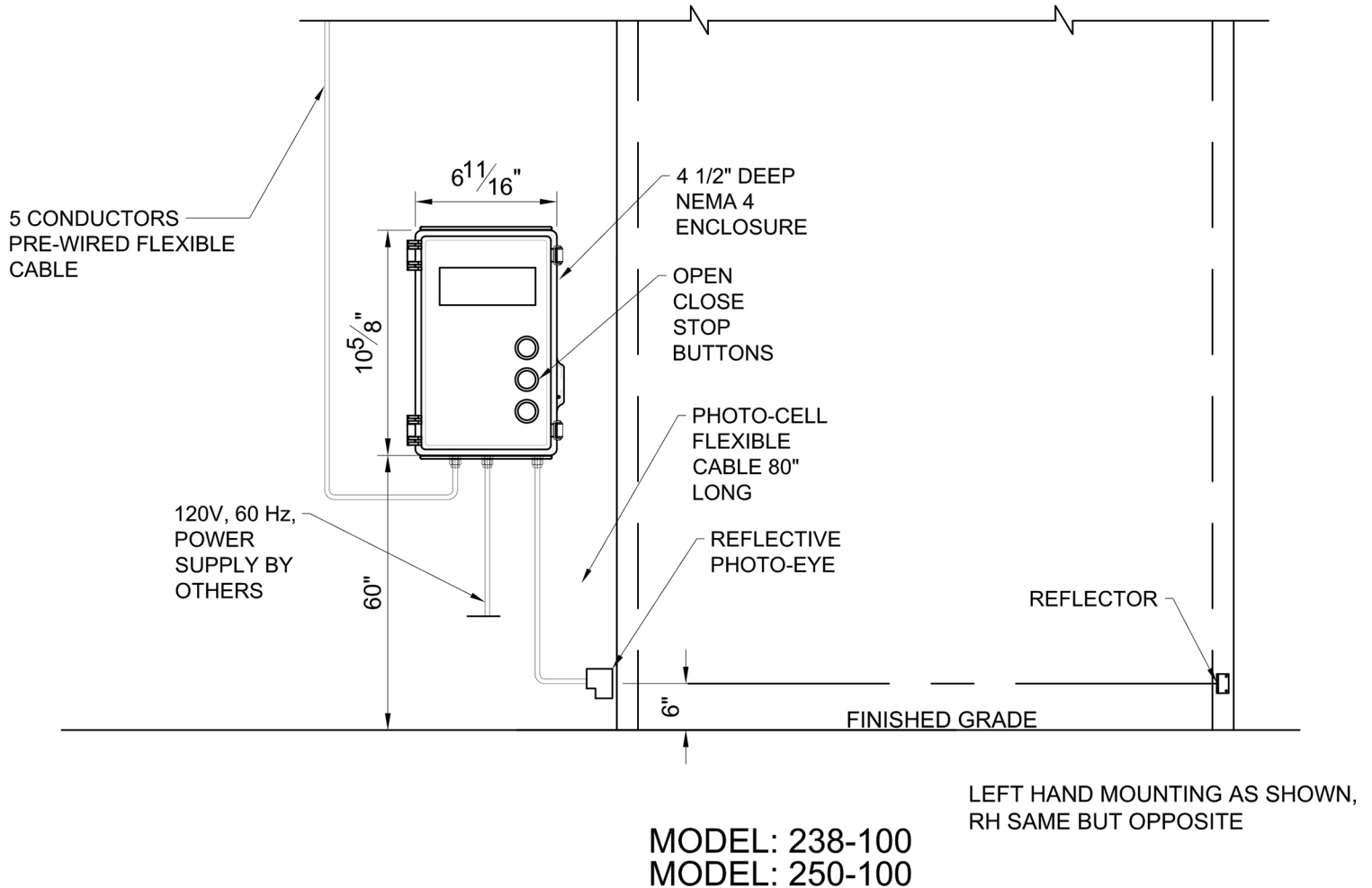

FIGURE: 8

Photo-Eye or Thru-Beam Sensor Mounting

The included reflective photo-eye or optional thru-beam sensor should be mounted so that it scans area that spans the entire width of the door at a height of no more than 6 inches from the ground. The sensor (reflective photo-eye) or receiver (thru-beam) should be mounted on the operator side (as it will be wired into the control panel), while the reflector or transmitter should be mounted on the opposite side of the door, facing the sensor/receiver so that its center meets the beam. Use the included mounting bracket(s) to secure to either the door tracks or the wall. Refer to the specific mounting details provided with the sensor. For final alignment of the sensor, apply power to the sensor (after completing WIRING - see page 10/11 for additional wiring info). Once properly aligned the indicator will light up in confirmation. See Fig: 8 for mounting reference.

WIRING INSTRUCTIONS

WARNING

TO REDUCE THE RISK OF PERSONAL INJURY OR DEATH, ENSURE THAT THE FOLLOWING PRECAUTIONS HAVE BEEN FOLLOWED PRIOR TO MAKING ELECTRICAL CONNECTIONS:

1. Disconnect power at fuse box/source and follow proper lockout/tag-out procedures per national and local electrical codes.
2. Ensure that all electrical connections are made by qualified electricians/technicians only and meet national and local electrical codes, and that the unit is properly grounded.
3. All wiring should be on a dedicated circuit and properly protected.

MOTOR CONNECTIONS

The Pulse 200 Series Operators are supplied with a 5 conductor 16AWG cable that is pre-wired to the junction box of the motor. This cable needs to be connected into terminals located in the control panel. All Control Panel connections, including power, motor and peripherals should be performed by an installation professional.

Run cable from Motor to the Control Panel in accordance with local and national regulations. Then wire as follows:

1. Motor Wires: Connect Black wire to M1, Red wire to M2 and Green wire to GND (Ground) terminals in control panel. Do not reverse polarity or motor will operate in the opposite of its intended direction.
2. Encoder Wires. Connect to Orange wire to E1 and White wire to E2 terminals in control panel. Do not reverse polarity or encoder will not work, and could suffer damage on power up.

POWER CONNECTIONS (110-130Vac Single Phase)

- 1. ENSURE POWER IS DISCONNECTED!**
2. Run power wires into control panel in accordance with local and national regulations.
3. Connect incoming power to L,L1 and N,L2, and GND (Ground).

DO NOT POWER UP UNIT UNTIL INSTALLATION IS COMPLETED FULLY AND YOU ARE PREPARED TO ALIGN PHOTO EYE AND SET LIMITS.

REFLECTIVE PHOTO EYE SENSOR

1. Once mounted, run the cable for the sensor into the control panel, and connect wires as follows:
Brown wire to PHOTO EYE V+, Black wire to PHOTO EYE IN, Blue wire to PHOTO EYE COM.

Wiring of Peripherals

The Pulse 200 Series Operators can accommodate added 24Vdc reversing devices (Photo-Eyes, Light Curtains, Reversing Edges, Etc.) and added 24Vdc activation devices (Remote Push Buttons, Remote Radio, Floor Loop, Pull Cord, Motion Detector, Photo Eye, Etc.) - contact iControls for more information. As well, there is an on board relay for interlocking or external communication for signalling devices, security systems, fire systems, etc. Furthermore, terminals for the addition of a 3rd party 24Vdc electric lock are provided as well as connections for a separately powered closed warning light.

NOTE: It may be required to drill an added hole into the control panel enclosure for wire access for peripherals. If doing so, DO NOT DRILL INTO THE PRINTED CIRCUIT BOARD OR BATTERIES, CLEAN ALL SHAVINGS/DEBRIS FROM INSIDE THE PANEL and USE APPROPRIATE CONNECTOR FOR CABLE ENTRY.

Battery Connections

The Pulse 200 Series come standard with Built-In Battery Backup that provides 24Vdc/2.3Ah of power for power-outage situations (mounted behind the board). Simply plug in the battery leads with female connectors to the headers found to the left of the LCD on the board as indicated in diagram below.

WIRING DIAGRAM

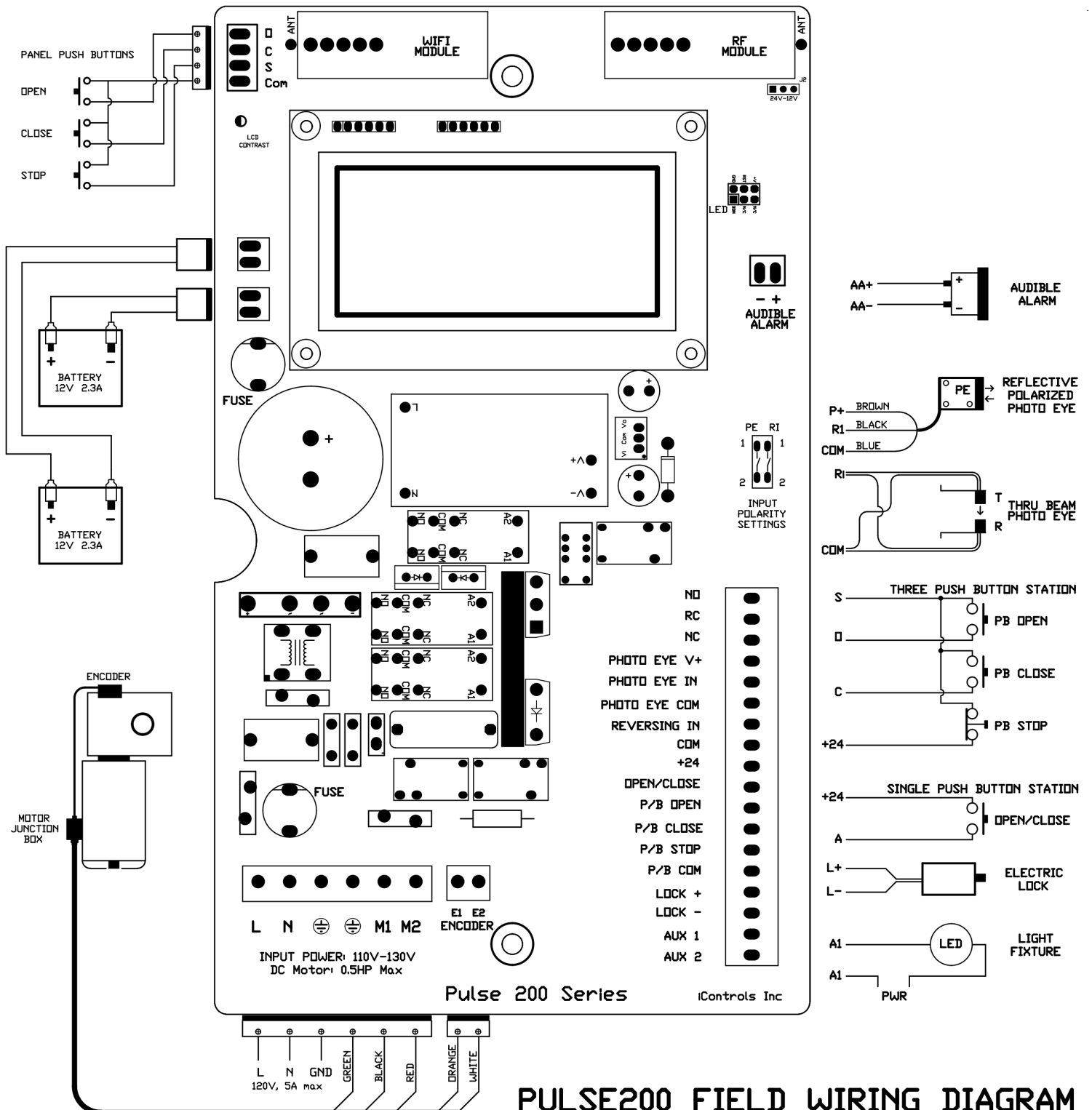

PULSE200 FIELD WIRING DIAGRAM

STARTUP PROCEDURE

CAUTION!

Before applying power to the Pulse operator, ensure that the unit is firmly in positioned on the door shaft and securely fastened to the torque arm/bolt, that the torque arm is anchored to structural support, and that Limit brackets are in place.

POWERING UP

Turn power on at source. The Control Panel LED Screen should light up and run a self-diagnostic. If LCD screen is not lit, refer to Trouble Shooting on Page 19. Once it has run through its self-diagnostic, the screen will read 'Door is Ready - Press Open to Start'. DO NOT TRY TO OPERATE THE DOOR AFTER INITIAL POWER UP - LIMITS MUST BE SET.

Once powered on, check Photo-Eye alignment - the yellow LED on top of the Photo-Eye should be lit if properly aligned with the reflector. If it is not, adjust until in proper position and the LED is lit. Once Photo-Eye is correctly aligned, move on to Menu Settings. DO NOT OPERATE DOOR UNTIL LIMITS HAVE BEEN SET (see below instructions).

SETTING LIMITS

Limits should be set before any other menu option. Before setting limits, ensure that the Reflective Photo Eye Sensor is properly installed and aligned, that the Limit Brackets are appropriately installed and that the power is on. The yellow LED on top of the Photo Eye Sensor should be lit. If it is not, recheck that the power is on and that the Sensor is appropriately aligned. If ready to set limits, move forward to the SETUP MENU selection DOOR LIMITS below.

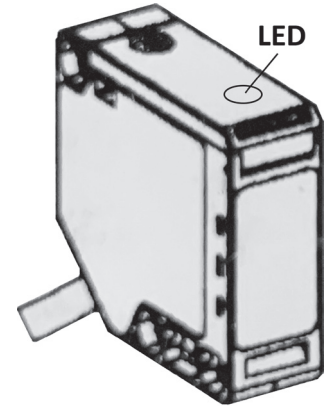

SETUP MENU - ACCESSING ALL MENU SELECTIONS

NOTE THAT ALL FACTORY MENU SETTINGS ARE RECOMMENDED FOR SECTIONAL DOORS ONLY. CONTACT iCONTROLS FOR SETTINGS FOR OTHER DOOR STYLES (i.e. Rolling Steel, etc.)

For access to the SETUP MENU press and hold the STOP button on the control board (bottom button beside the LCD screen) for 10 Seconds - do not release until SETUP MENU appears on the screen. Once done, you can scroll between the various SETUP MENU options by pressing the OPEN and CLOSE buttons. Once you have reached a selection that you would like to change, press the STOP button. Use the OPEN and CLOSE buttons to scroll/toggle between options within the selection, and then press STOP to save your selection and return to the SETUP MENU.

DOOR LIMITS

NOTE: PROGRAMMING OF LIMITS SHOULD BE PERFORMED BY TRAINED PERSONNEL ONLY. THE ENCODER WILL RETAIN THESE LIMITS UNLESS REPROGRAMMED.

Press the STOP button to set the limits. Once selected, DOOR LIMITS heading will appear with a prompt to 'Push OPEN to Start'. Push the OPEN button, and the door will open to the fully open position against the Limit Brackets at a slow, controlled speed. ENSURE THAT THE TOP ROLLERS OF THE DOOR ARE RESTING AGAINST THE LIMIT BRACKETS. You will now be prompted to Set the Open Limit.

SET OPEN LIMIT

Press CLOSE (OPEN button is functional should you overshoot desired position) to jog the door to the desired Open Limit height. **The Open Limit Setting Should be a minimum offset of 3" from the Limit Bracket.** Press STOP button to save Open Limit and advance to SET CLOSE LIMIT.

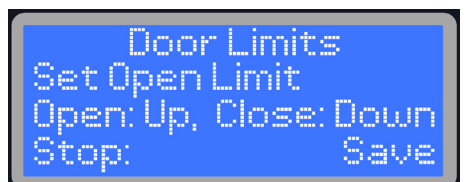
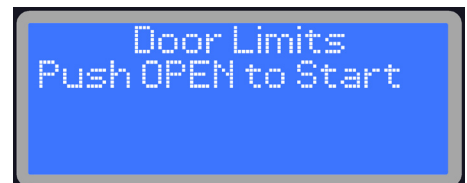
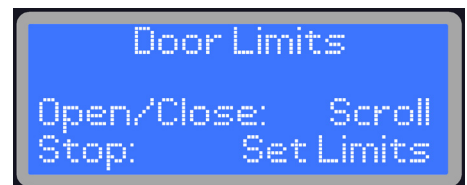

SET CLOSE LIMIT

From the Open Limit, jog to the desired Close position, using the CLOSE button (OPEN available for fine tuning). Ensure that the door is properly sealed at the bottom.

Press STOP button to save and return to SETUP MENU.

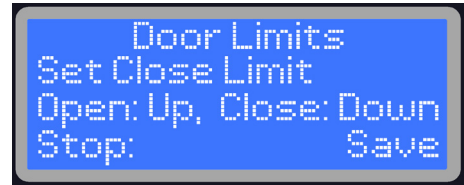

SETTING DOOR SPEEDS

On initial set up please use the factory default speed settings (3 for OPEN, 2 for CLOSE). As noted below the Motor, Door and Drum size may affect the opening speed of the door and the default settings may be all that is required to achieve 24" per second opening speed. Test door at factory setting prior to making adjustments.

Please note that the Pulse has been developed with the same technology that is used in High Speed Door Operators. While we have limited the maximum opening speed to ~24" per second for sectional doors (this is dependent on the type of door and drum used) and maximum closing speed to ~16" per second, we recommend that you set the speed to accommodate both your requirement, and the hardware of the door. To get the longest life out of your door, and to maximize your allowable speed, we recommend Stainless Steel cables and nylon rollers be installed if they are not already standard on your door.

OPENING SPEED

To access the Open Speed Settings, ensure you are in SETUP MENU (see above instructions), then toggle between options using the OPEN or CLOSE buttons until Open Speed appears on the screen. Then press the STOP button to access and make changes.

The Pulse 200 operator is factory equipped with 5 options of open speed settings. Toggle between these 5 options (1-5) by using the OPEN and/or CLOSE buttons, and press the Stop button once the desired selection appears on the screen to save and return to the SETUP menu.

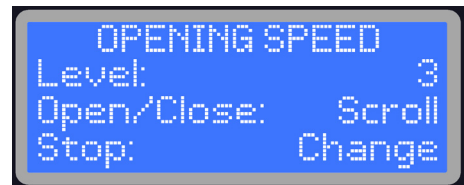

CLOSING SPEED

To access the Closing Speed Settings, ensure you are in SETUP MENU (see above instructions), then toggle between options using the OPEN or CLOSE buttons until Close Speed appears on the screen. Then press the STOP button to select.

The Pulse operator is factory equipped with 5 options of close speed settings. Toggle between these 5 options (1-5) by using the OPEN and/or CLOSE buttons, and press the Stop button once the desired selection appears on the screen to save and return to the SETUP menu.

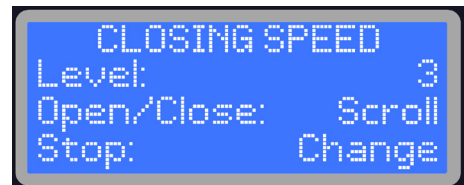

CLOSING TIMER

IT IS NOT RECOMMENDED TO SET THE CLOSING TIMER UNTIL AFTER THE UNIT HAS BEEN FULLY TESTED.

The Closing Timer will automatically close the door after opening by the preset number of seconds that have been programmed using this STARTUP MENU option.

Once you have accessed this option, use the OPEN and CLOSE buttons to increase or decrease the closing timer value in 1 second intervals. If it is not required, ensure that the Closing Timer is set to OFF. If it is required, set it to any number of seconds from 1 to 99. Remember that this is the number of seconds that the door will remain open before automatically closing. Press the STOP button to save the value and return to the SETUP MENU.

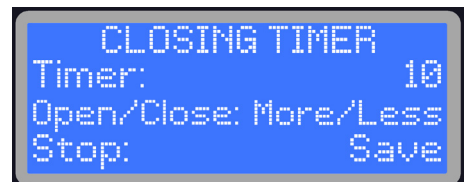

The Closing Timer will de-activate in the event that the Photo-Eye is in a fault condition (blocked, misaligned, damaged), and manual Push and Hold to Close protocols (constant pressure) will apply to door closing operations.

CLOSING FORCE

If the door is obstructed from closing (ie. due to obstruction, jam, etc.) this current monitoring feature will stop and reverse the door to prevent damage. The sensitivity of this monitoring can be changed in this setting, or the feature can be turned off entirely.

Closing Force sensitivity can be adjusted from 1-49 (1 being most sensitive to obstructions/jams/imbalance) or OFF. Factory default is '5'. Note that if this setting is turned to OFF, Push & Hold to Close protocol (constant pressure) will be initiated per UL325.

```
CLOSING FORCE
Level          10
Open/Close:   More/Less
Stop:         Save
```

OPENING FORCE

If the door is obstructed from opening (ie. due to ice buildup, the door latch is engaged, etc.) this current monitoring feature will stop the door to prevent damage. The sensitivity of this monitoring can be changed in this setting, or the feature can be turned off entirely.

Opening Force sensitivity can be adjusted from 1-99 (1 being most sensitive to obstructions/jams/imbalance) or OFF. Factory default is '10'.

```
OPENING FORCE
Level          10
Open/Close:   Scroll
Stop:         Change
```

OPEN RAMPDOWN DISTANCE

This setting is used to change the point where the door begins to decelerate to slow speed as it approaches the Open Limit. The user can choose between auto (which is configured by the system) or the desired number of shaft rotations (between 0.5 turns and 3 turns in half rotation increments).

The Factory default setting for this feature is AUTO. This should not be changed unless recommended by Pulse Technical Support.

```
OPEN RAMPDOWN
Set at:        2.5 Turns
Open/Close:   Scroll
Stop:         Save
```

CLOSE RAMPDOWN DISTANCE

This setting is used to change the point where the door begins to decelerate to slow speed as it approaches the Close Limit. The user can choose between auto (which is configured by the system) or the desired number of shaft rotations (between 0.5 turns and 3 turns in half rotation increments).

The Factory setting for this feature is AUTO. This should not be changed unless recommended by Pulse Technical Support.

```
CLOSE RAMPDOWN
Set at:        Auto
Open/Close:   Scroll
Stop:         Change
```

OPEN SLOW SPEED

When the door is approaching open limit and decelerates to slow speed before the stop (Soft Stop), added force/speed may be required to complete opening. While this is indicative of an improperly balanced door, this feature can be used to compensate. This setting should only be changed from the NORMAL to the HIGH setting if door becomes unbalanced over time and does not completely travel to Open limit. If it is a new installation, changing the spring tension for proper balance is a required first step. Factory default is 'NORMAL'.

```
OPEN SLOW SPEED
Set at:        Normal
Open/Close:   Scroll
Stop:         Change
```

CLOSE SLOW SPEED

When the door is approaching Close Limit and decelerates to slow speed before the stop (Soft Stop), added force/speed may be required to complete closing. While this is indicative of an improperly balanced door, this feature can be used to temporarily compensate. This setting should only be changed from the NORMAL to the HIGH setting if door **becomes** unbalanced over time and does not completely travel to Close limit. If it is a new installation, changing the spring tension for proper balance is a required first step. Factory default is 'NORMAL'.

```
CLOSE SLOW SPEED
Set at:        Normal
Open/Close:   Scroll
Stop:         Change
```

PWM FREQUENCY

This Setting allows the user to change the operating frequency for the motor between 2.4 kHz, 12kHz and 20kHz. Certain frequencies can interfere with third-party accessories, or create an electronic hum, and adjustment may be necessary. Factory default is set to 12kHz. Do not alter this setting unless advised by Technical Support.



OUTPUT RELAY OPTIONS

The Output Relay is used for signalling/interlocking with other devices such as a dock leveller, security equipment, other doors, etc. There is one NO and one NC contact available that can be energized at either the open or closed limit, or between limits, as chosen by the user in this setting.

The Factory setting for this feature is ENERGIZED WHEN OPEN.

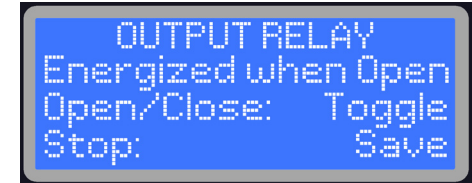

LOCK OUTPUT

To access the Lock Output Setting, ensure you are in SETUP MENU (see previous instructions), then toggle between options using the OPEN or CLOSE buttons until Lock Output appears on the screen. Then press the STOP button to alter Setting.

The Lock Output function is needed to be activated only when a 3rd party 24Vdc powered lock is connected to the Lock+ and Lock- terminals. This will allow for engagement and disengagement of the lock device when the door is closed and prior to opening. The delay time for door movement (to accommodate for lock release) is adjustable between 100-500ms (Factory Default is 'OFF'). Note that the batteries must be connected to enable lock output functionality.



JOG MODE

To access the Jog Mode Setting, ensure you are in SETUP MENU (see previous instructions), then toggle between options using the OPEN or CLOSE buttons until Jog Mode appears on the screen. Then press the STOP button to begin using.

Jog Mode enables manual control of the door using the OPEN and CLOSE buttons. During Jog Mode, all limits are de-activated, and push-hold protocols are initiated. This selection can be used to test door functionality without the encoder, ensure proper door balance, or as a method to operate the door under power should the encoder malfunction. It is also effectively used if you are experiencing any encoder issues. The door will travel in each direction at the set OPEN SLOW SPEED and CLOSE SLOW SPEED (see Page 14) for safe operation.

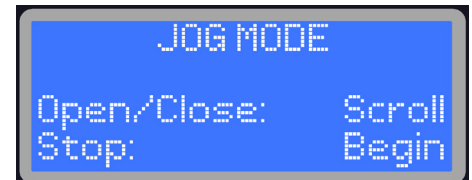

CALIBRATION

This feature is required to calibrate force monitoring levels. Re-calibration is generally required when the door begins, over a period of time, to reverse or stop due to a consistent sensing of over-current. This could be due to any number variables including sharp changes in temperature, spring relaxation, etc. Calibration can be reset via the SETUP Menu, or manually without having to enter the Setup Menu. It is generally not required to select this menu setting during initial setup as the Pulse Operator will prompt for calibration upon exit from menu, if required.

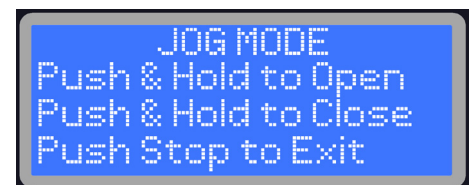

NOTE: IF YOU CHANGE ANY OF THE FOLLOWING SETTINGS, THE OPERATOR WILL PROMPT FOR RECALIBRATION WHEN EXITING THE MENU: Door Limits, Open Speed, Close Speed, PWM Frequency, Open Rampdown and Close Rampdown.

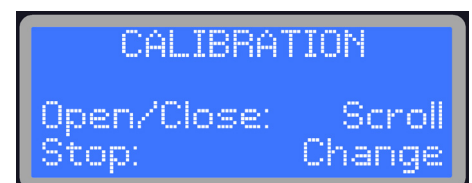

RECALIBRATING FROM THE OPERATOR PANEL USING MENU:

- Select CALIBRATION from the SETUP MENU
- Press Open per the screen prompt to begin automatic slow opening cycle of the door to the Limit Brackets for Encoder Reset
- Press the CLOSE button per prompt to Calibrate Closing Force. If a reversing device is activated, the Operator will abort and prompt you to start again.
- Once Door is Closed, you will be prompted to Press Open to Calibrate Open Force. Door will open at set speed.
- Once the door has opened, Calibration is complete. You will need to exit the menu before normal operation of the door can begin (unless this calibration was prompted at SETUP MENU exit).

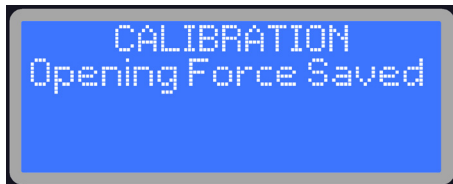
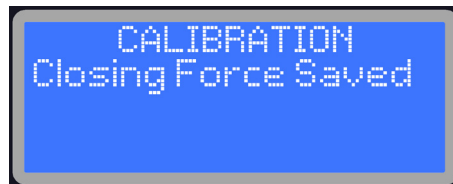

RECALIBRATING WITHOUT USING MENU:

- Ensure that the door is in the OPEN position
- PRESS & HOLD the Close Button until the door is completely closed and has stopped moving.
- Closing Force Calibration is now complete. Opening Force Calibration will occur the next OPEN operation. Expedite this by pressing Open now.

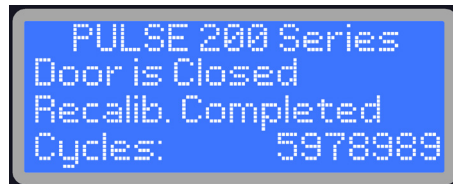

BALANCE CHECK

Once selected from the menu, the door will automatically run through one full close/open cycle (after an encoder reset). It will then report on the screen values representing the force required to open and to close the door. The difference in these numbers represents the imbalance, and adjustments to the spring tension should be made accordingly. Run this feature again to verify proper adjustment.



FACTORY RESET

This setting allows for a reset of all menu options to the factory default. These are the Factory Settings:

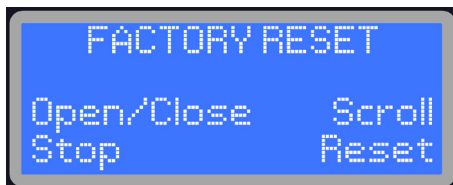

SETUP MENU

Closing Timer:	OFF
Door Limits Setup:	4 Rotations - Must be Re-Programmed by Installer
Open Speed:	3
Close Speed:	2
Opening Force:	10
Closing Force:	4
Open Rampdown:	Auto
Close Rampdown:	Auto
Open Slow Speed:	Normal
Close Slow Speed:	Normal
PWM Frequency:	12 kHz
Output Relay:	Energized When Open

After performing factory reset (if deemed necessary), adjust settings as required, and re-program limit settings and perform calibration thereafter.

EXITING SETUP MENU - CALIBRATION & TESTING

To exit from the Setup Menu, press and release the STOP button while SETUP MENU appears on the LCD. If you have saved changes to the operator speed, PWM Frequency, Open or Close Rampdown, or reset limits, you will be required to do a quick system calibration. Screen prompts will provide real-time instruction on calibration requirements. See Pages 15-16 for more detailed information on Calibration.

Once Calibration is completed or if it was not required, the system will run a quick diagnostic, and the LCD will read indicate its current position (OPEN, CLOSED or STOPPED). The door is now ready for use. BEFORE OPERATING THE DOOR, ENSURE THAT THE DOOR LIMITS HAVE BEEN SET.

Testing of the door is now required. Observe whether the door is running smoothly and is stopping at the appropriate limits. Ensure that the door is set at the required speeds, and test each reversing and activation device to confirm their functionality.

PATENTED BATTERY BACKUP - POWER OUTAGE OPERATION

The Pulse is factory equipped with a patented battery backup system and it is automatically activated during a power outage. This battery backup even works if there is board damage occurring due to external forces such as lightning or impact. While normal power is on, the built-in trickle charger optimizes the battery life for ready use.

To operate under battery power when the main power is out, simply push and hold the OPEN button in order to open the door, or push and hold the CLOSE button in order close the door. Note that the door will move in its appropriate direction, but speeds will be reduced. All safety devices will be disabled during a battery backup operation and any personnel operating the door should maintain a clear line of sight with the doorway in order to reduce the risk of possible door impact with personnel or equipment, and to ensure the door operates safely. To enable and test battery backup functionality when the power is available, please disconnect the power to the operator.

DO NOT CONTINUE TO HOLD THE OPEN OR CLOSE BUTTON PAST ITS INTENDED LIMIT - YOU MAY BLOW THE FUSE.

In case the batteries are fully drained or missing, the base of the motor is also equipped with a 3/8" ratchet entry. **TURN OFF POWER TO THE OPERATOR** (even if the power seems out), secure a crankshaft, socket wrench or power drill with 3/8" ratchet head (not included) inside the ratchet entry and rotate it in the appropriate direction in order to open or close the door. Turn on the power once manual operation is no longer required.

NOTE ON BATTERIES

Provided lead-acid batteries are 2 x 12V connected in series to provide 24Vdc. The controller provides a monitored trickle charger in order to maintain the batteries' life. Should the batteries be fully drained and no longer accept a charge, please replace them with equivalent batteries (available from iControls), and dispose of the expired units according to local environmental regulations.

CAR WASH/WATER-RESISTANT APPLICATIONS

iControls recommends an available upgrade for all Car Wash/Water Resistant applications. Standard Pulse Operator Drives are rated IP44, and could be vulnerable to water ingress. Furthermore, reflective photo-eye sensors have a tendency to be detrimentally affected by condensation on the reflector, preventing reliable operation in such conditions. iControls offers a cost-effective Water-resistant upgrade that both seals all ingress points on the motors, and includes a thru-beam sensor in place of a reflective photo-eye. Please contact iControls for details and pricing.

REMOTE TRANSMITTERS

Local range remote controls are provided with every Pulse 200 residential operator. Please note that these have been pre-linked and should work out of the box. Should re-pairing be required, or pairing with other 315MHz devices prove necessary, please contact iControls for detailed instructions.

PULSE OPERATOR COMPONENTS

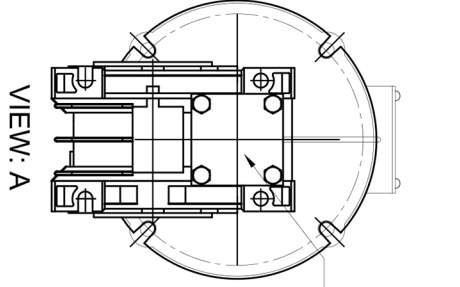

VIEW: A

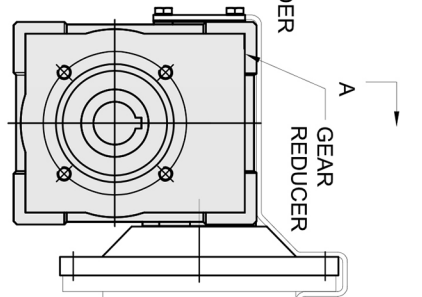

ELEVATION

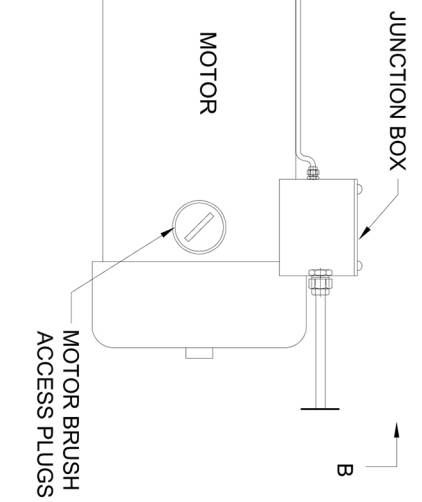

VIEW: B

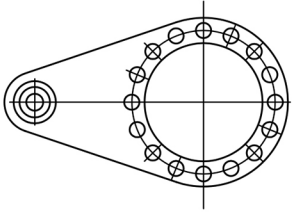
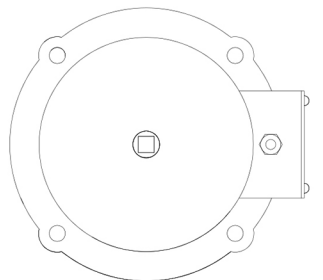

(1) TORQUE ARM

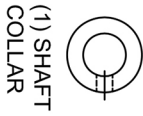

(1) SHAFT COLLAR



(1) BENT KEY



(4) 1/4 x 20 HEX HD BOLTS, FWASHERS, LOCK NUTS



(4) M8 BOLTS



(1) REFLECTOR



(1) REFLECTIVE PHOTO EYE

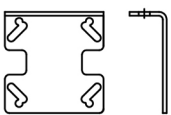

(1) PHOTO EYE BRACKET.



(1) 3/8" DIA. BOLT,
(2) WASHERS,
(1) NUT

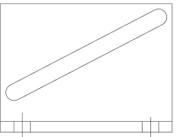

(1) TORQUE ARM BRACKET



(2) OPEN/STOP TRACK ANGLE



(2) 12 V, 2.3Ah BATTERIES

OPERATOR: SERIES 100

iControls[®]
Richmond Hill, Ontario.

TROUBLE SHOOTING GUIDE

The following are common user experienced problems that are easily diagnosed and quickly resolved during installation and operation of a Pulse 100 Series operator.

If, after reviewing the trouble shooting guide you are unable to resolve whatever issue you may be experiencing, please call our toll-free technical support line for assistance.

PULSE OPERATOR TOLL-FREE TECHNICAL SUPPORT: 1-833-785-7332

SYMPTOM	PROBABLE CAUSE	SUGGESTED ACTION
NO DISPLAY AT THE LCD PANEL	NO POWER	Check power is on at circuit breaker, disconnect switch is on, and ensure unit is plugged in.
		Check power fuse in panel (6.3A Time Delay, beside power connections in lower left corner).
DOOR STOPS AT RANDOM POSITION DURING OPENING	OPENING FORCE IS TOO SENSITIVE	Adjust the Opening Force setting in the SETUP MENU. 1 is most sensitive, and 30 is least sensitive.
	OBSTRUCTION/DOOR JAMMED	Check that there is nothing external interfering with door operation causing Opening Force to activate.
DOOR REVERSES BEFORE REACHING CLOSE POSITION OR AS SOON AS THE CLOSE BUTTON IS RELEASED	PHOTO-EYE/REFLECTOR MISALIGNED OR OBSTRUCTED	Clean, re-align and/or clear obstruction in front of the sensors/reflector. Confirm yellow LED on Photo Eye is on.
	CLOSING FORCE IS TOO SENSITIVE	Adjust the Closing Force setting in the SETUP MENU. 1 is most sensitive, and 30 is least sensitive.
	THIRD PARTY REVERSING DEVICES MALFUNCTIONING	Disconnect third party reversing devices and test again. If working, reconnect reversing devices one at a time to isolate the defective device or miswiring.

TROUBLE SHOOTING GUIDE

SYMPTOM	PROBABLE CAUSE	SUGGESTED ACTION
'DOOR IS STOPPED' MESSAGE ON LCD PANEL	OBSTRUCTION OR DOOR JAMMED DUE TO OBSTRUCTION.	Remove obstruction or free up the door, turn "OFF" the AC power and cycle test the door under battery power.
	PUSHER SPRINGS OR LIMIT BRACKETS MAY BE PREVENTING DOOR FROM REACHING THE OPEN LIMIT.	Reset OPEN limit so that Pusher Springs are not significantly engaged or that rollers are at least 3 inches from the limit brackets at set limit.
	DOOR NO LONGER BALANCED PROPERLY	Run 'BALANCE CHECK' in SETUP MENU and make required balance adjustment.
DOOR MOVES FEW INCHES AFTER OPEN/CLOSE COMMAND AND STOPS	THIRD PARTY PUSH BUTTON DOES NOT HAVE AN NC (NORMALLY CLOSED) CONTACT FOR THE STOP BUTTON.	Replace the push button station (or the contact for the STOP button) for one that has an NC contact on the STOP button. Wired unit from factory is compliant.
	THIRD PARTY PUSH BUTTON STATION WIRED INCORRECTLY.	Check and correct wiring as necessary.
DOOR DOES NOT CLOSE ON REMOTE OR CLOSE TIMER	PUSHER SPRINGS MAY BE PREVENTING DOOR TO OPEN FULLY TO THE OPEN LIMIT (SCREEN READS 'DOOR IS STOPPED') .	Reset Open Limit so that it does not engage pusher springs.
	CLOSE TIMER NOT SET OR NOT SET APPROPRIATELY.	Enter Menu, and ensure that Closing Timer is set for desired delay.
	PHOTO EYE IS BLOCKED, MISALIGNED OR DAMAGED.	Check that the LED light on the Photo-Eye is on. If not, Clean Photo-Eye and Reflector. If still not on, Check Alignment. If still not on, check for damage to Photo-Eye or Photo-Eye Cable.
'NO MOTION DETECTED' MESSAGE ON LCD PANEL	DOOR IS OBSTRUCTED OR JAMMED.	Ensure that door latch is disengaged. Check for obstruction or that door is jammed in tracks. Turn off power and cycle test the door under battery power while monitoring for physical snags/obstructions.

TROUBLE SHOOTING GUIDE

SYMPTOM	PROBABLE CAUSE	SUGGESTED ACTION
DOOR DOES NOT WORK ON BATTERY POWER	BATTERY FUSE MAY BE BLOWN	Test Fuse in Vertical black Fuse Holder. Replace Fuse (6.3A Time Delay) if necessary.
	BATTERIES MAY BE DRAINED OR DEAD	Check batteries voltage, if low let it charge for 24 hours with AC power ON. Replace batteries if still not charged.
	DOOR IMPROPERLY BALANCED	Run 'BALANCE CHECK' in STARTUP MENU and make required balance adjustment.
	MAIN POWER STILL BE ON	Unplug unit to ensure the main power is off.
FORCE MONITORING NOT WORKING	CLOSING/OPENING FORCE IS NOT SET PROPERLY	Adjust the Closing and/or Opening Force. Directions are shown on Pages 13/14. Increase or decrease based on door weight/size, door type/age and door hardware.

PULSE OPERATOR REPLACEMENT PARTS

iControls can provide replacements for all components on the Pulse 200 Operators in the event of damage, wear or failure. Please contact our Technical Assistance team at 1-833-785-7332 and we will assist you with the diagnosis of the issue and identification of any and all necessary parts. These parts could include, but are not limited to:

MOTOR
MOTOR BRUSH SET
GEARBOX
CONTROL ENCLOSURE
PRINTED CIRCUIT BOARD - CONTROL
PRINTED CIRCUIT BOARD - ENCODER
PRINTED CIRCUIT BOARD - REMOTE RECEIVER
REMOTE TRANSMITTER
PUSH BUTTONS
TORQUE ARM
TORQUE ARM BRACKET
LIMIT STOPS/HARDWARE KIT
SHAFT COLLAR/KEY
BATTERY
PHOTO-EYE SENSOR/BRACKET
PHOTO-EYE REFLECTOR

Should you require any of the above, our team will provide you with part numbers and direct you to the nearest distributors that can provide you with the items as quickly as possible.



PULSE 200 WARRANTY

Coverage

Pulse 200 Series Operators are fully warranted for a period of 2 years or 250,000 cycles (whichever comes first) from their purchase date. This warranty is inclusive of, and limited to, all component and manufacturing defects only, and does not cover possible failure due to external forces including irregularities caused by impact, improper installation and/or connection, voltage surges and any and all other user and/or environmentally caused failures. This warranty is valid for replacement or repair of defective product only, and does not include any labour incurred for the removal or installation of defective part(s), re-installation of replacement/repaired product, shipping charges for the return of the product, or other possible costs related to the inoperability of the operator. Coverage does not extend to maintenance of Motor Brushes which should be replaced every 200,000 cycles.

Software reliability and performance is also covered under our warranty, but does not include software updates, upgrades and/or custom modifications unless so authorized in writing by iControls.

Claims

Before making a warranty claim, please call Pulse Tech Support at 1-833-785-7332 and ask for troubleshooting assistance. **DO NOT REMOVE THE PRODUCT**, until so authorized.

Note

Upon request, iControls can also provide field assistance (additional fees may apply) and/or advice with installation, troubleshooting, product enhancement or improvement of our product.

Under the terms of this limited warranty, for any door components that are found to be defective upon inspection by authorized iControls personnel, iControls will replace the defective door components. Labour charges for installation or repairs shall be the responsibility of the customer and must be performed by an authorized iControls Dealer. This warranty applies only to doors that are professional installed by an authorized iControls dealer. In the case that the operator or part is discontinued or becomes obsolete, iControls reserves the right to replace the product with a suitable alternative.

iControls shall not be liable for any consequential or incidental damages. All other warranties, express or implied, including any warranty of merchantability, are hereby expressly excluded. Some jurisdictions do not allow the exclusion or limitation of consequential or incidental damages, so the above limitation or exclusion may not apply to you. This warranty gives you specific legal rights, and you may also have other rights which vary from jurisdiction to jurisdiction. To make a claim under these warranties, contact iControls.

35 East Beaver Creek, Unit 1, Richmond Hill, Ontario Canada L4B 1B3

905-597-8989 • www.iControls.ca • sales@iControls.ca

PULSE TECHNICAL SUPPORT LINE: 1-833-PULSEDC (1-833-785-7332)